

1 2 3 4 5 6 7 8 9 10 11 12 13 14 15 16

A B C D E F G H J K L M N P Q R S T U

A B C D E F G H J K L M N P Q R S T U

TOP VIEW

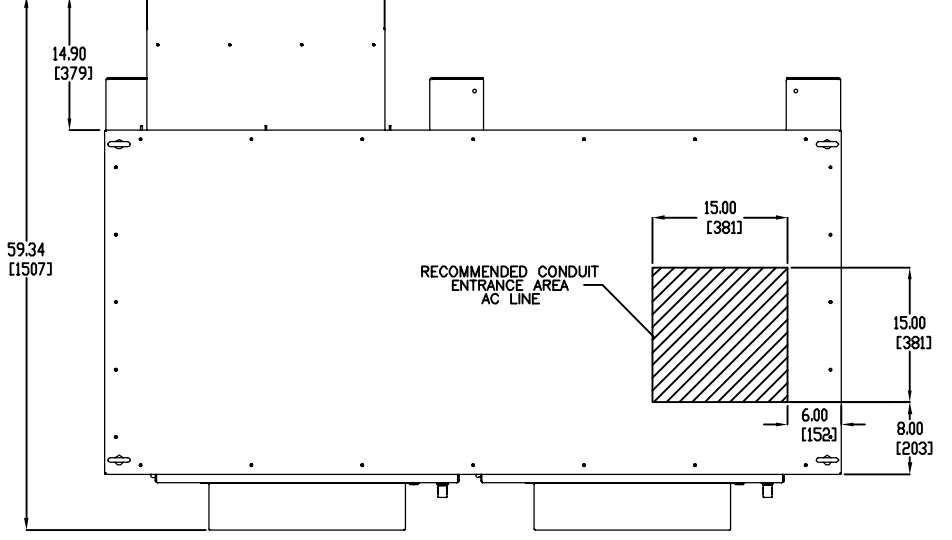

FRONT VIEW

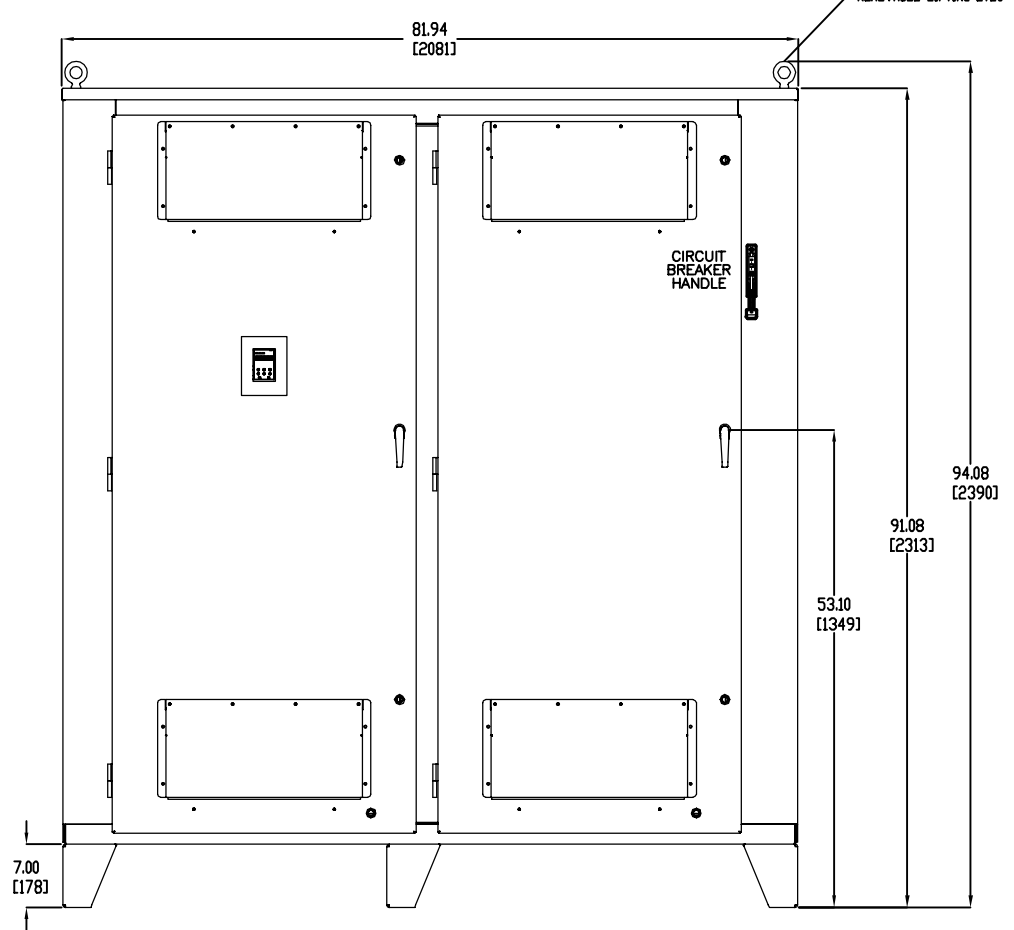

SIDE VIEW

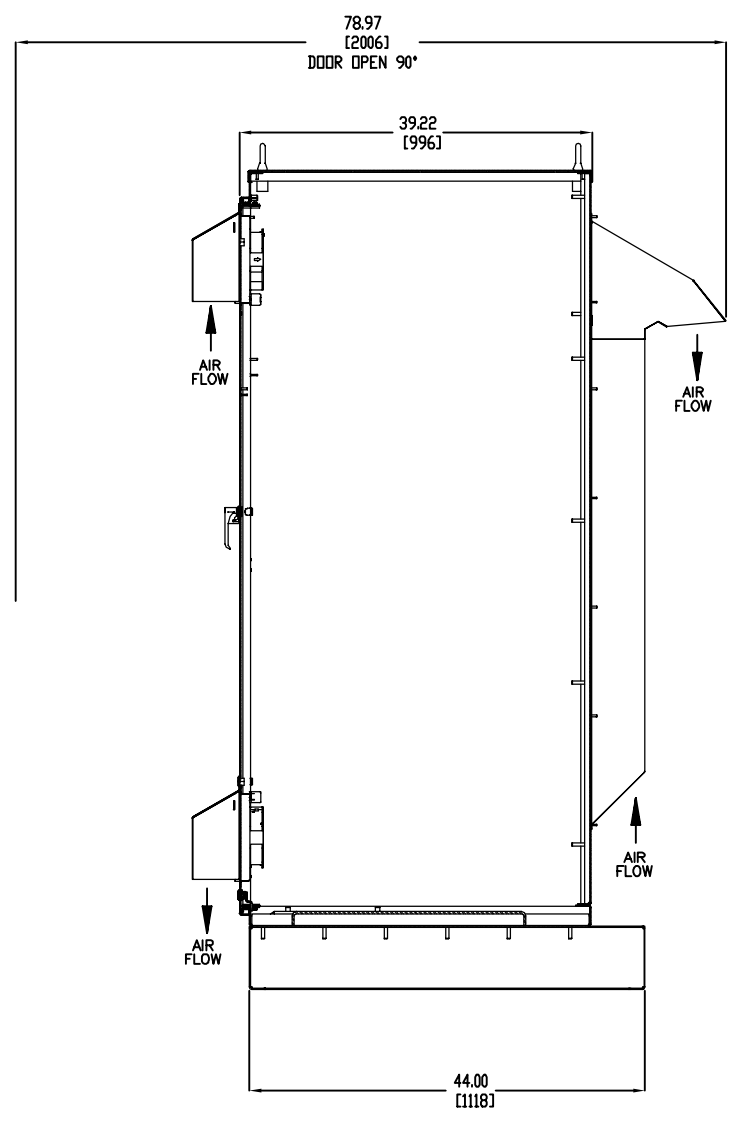

BOTTOM VIEW

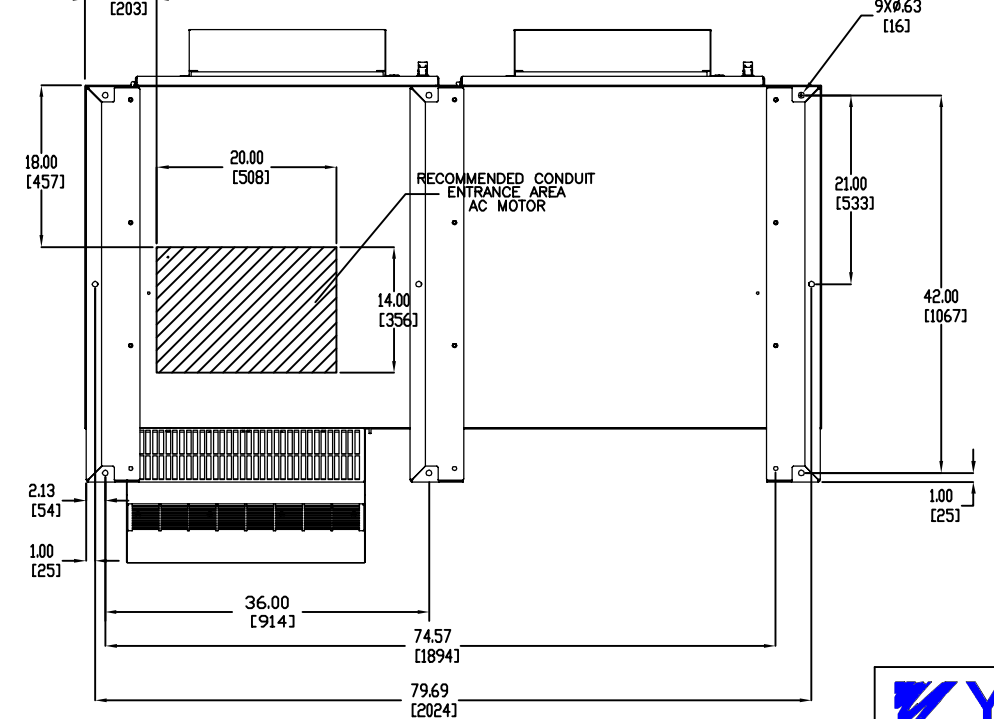

		DRAWN BY: P. STOCKUS	DATE: 12/9/13	TITLE: OUTLINE DIAGRAM TYPE 3R F2A ENCLOSURE		
		CHECKED: D. TUMILSON	DATE: 12/9/13			
THIS DOCUMENT AND INFORMATION CONTAINED IN IT ARE CONFIDENTIAL, AND CANNOT BE COPIED OR DISCLOSED IN WHOLE OR IN PART WITHOUT THE EXPRESS WRITTEN CONSENT OF YASKAWA AMERICA INC.		TECH:	DATE:	SIZE: C	REVISION: R01	PAGE: 1 of 1
		APPROVED: P. STOCKUS	DATE: 12/9/13	DRAWING #: Q1C3J590-50		
		ORIGINAL DESIGN: P. STOCKUS	DATE: 12/9/13			

REVISIONS

REV.	DESCRIPTION	ECO #	DRAWN BY	DATE
01	CHANGED TO F2A CABINET	5448	NSL	8/11/14
00	INITIAL RELEASE	-	PS	12/9/13

1 2 3 4 5 6 7 8 9 10 11 12 13 14 15 16